

TIM CAMPBELL 800-400-7500

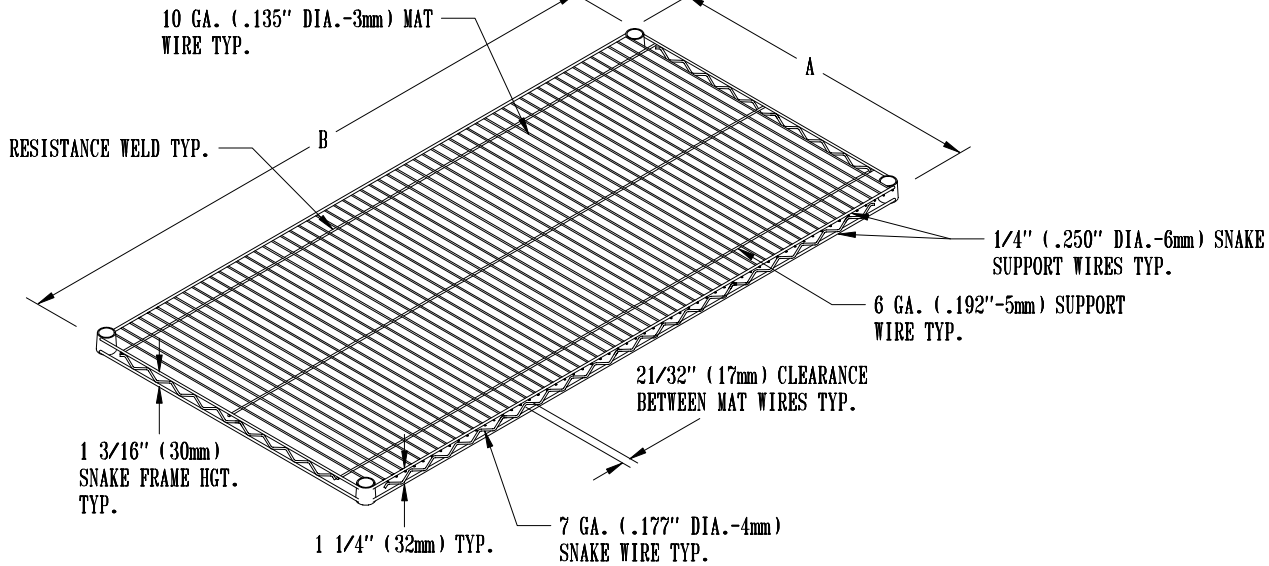

Dimensional Data - SES

Nom. Shelf Depth (in.) (mm.)	Actual Depth "A" (base of collars) (in.) (mm.)		Post Centers (Depth) (in.) (mm)		Number of Center Snakes	Nom. Shelf Length (in.) (mm.)	Actual Length "B"(base of collars) (in.) (mm.)		Post Centers (Length) (in.) (mm.)	
14 356	14-1/8	359	12.666	322	1424 thru 1448 (none) 1460 and 1472 (1)	24 610	23-7/8	606	22.416	569
18 457	18-1/8	461	16.666	423	1824 thru 1848 (none) 1854 thru 1872 (1)	30 762	30-7/8	759	28.416	722
21 533	21-1/8	537	19.666	500	2124 thru 2172 (1)	36 914	35-7/8	911	34.416	874
24 610	24-1/8	613	22.666	576	2424 thru 2460 (1) 2472 (2)	42 1067	41-7/8	1064	40.416	1027
30 762	30-1/8	765	28.666	728	3036 thru 3072 (3)	48 1219	47-7/8	1216	46.416	1179
36 914	36-1/8	918	34.666	881	3636 thru 3672 (3)	54 1372	53-7/8	1368	52.416	1331
						60 1524	59-7/8	1521	58.416	1484
						72 1829	71-7/8	1826	70.416	1789

NOTE: For overall dimensions when using 3-1/2" dia. (89mm) donut bumpers: add 2-3/16" (56mm) to nominal depth, and 2" (51mm) to nominal length. When using 5-1/2" dia. (140mm) donut bumpers: add 4-3/16" (106mm) to nominal depth, and 4" (102mm) to nominal length.

Application Chart - SES

Finish	Temp.	Abrasion	Chip Res.	Corrosion (Salt Spray)	Cut Through	Cart Wash	Finish Warranty	NSF Listed
Nickel Chrome	-20/120° F. -29/49° C.	Very Good	Excellent	Very Good	N/A	Not Recommended	1 Year	Yes
Brite	-20/120° F. -29/49° C.	Very Good	Very Good	Fair	N/A	Not Recommended	1 Year	Yes
Metroseal 3	-20/120° F. -29/49° C.	Excellent	Excellent	Excellent	Excellent	Not Recommended	12 Years	Yes
Stainless	-20/120° F. -29/49° C.	Excellent	Excellent	Excellent	N/A	Excellent	1 Year	Yes
Designer	-20/120° F. -29/49° C.	Good	Fair	Good	Fair	Not Recommended	1 year	No

NOTE: Use of aluminum split sleeves on nickel chrome, Metroseal 3, and Designer Shelving in stationary applications will increase maximum continuous temperature to 250° F. (121° C.), and stainless steel to 500° F. (260° C.) For all other applications, consult your Metro representative.

TIM CAMPBELL 800-400-7500 SUPER ADJUSTABLE SHELF DETAIL

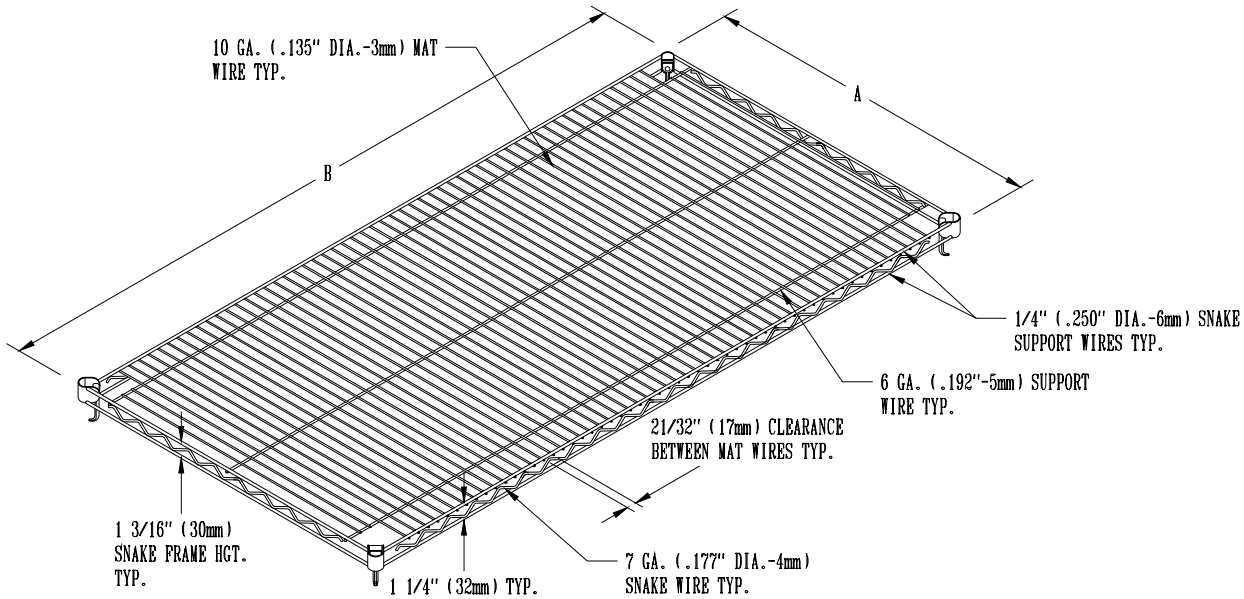

Dimensional Data - SASE

Nom. Shelf Depth (in.) (mm.)	Actual Depth "A" (in.) (mm.)		Post Centers (Depth) (in.) (mm)		Number of Center Snakes	Nom. Shelf Length (in.) (mm.)	Actual Length "B" (in.) (mm.)		Post Centers (Length) (in.) (mm.)		
	in.	mm.	in.	mm.			in.	mm.	in.	mm.	
14	356	14	356	12.694	322	24	610	23-3/4	603	22.444	570
18	457	18	457	16.694	424	30	762	29-3/4	756	28.444	722
21	533	21	533	19.694	500	36	914	35-3/4	908	34.444	875
24	610	24	610	22.694	576	42	1067	41-3/4	1060	40.444	1027
30	762	30	762	28.694	729	48	1219	47-3/4	1213	46.444	1180
36	914	36	914	34.694	881	54	1372	53-3/4	1365	52.444	1332
						60	1524	59-3/4	1528	58.444	1484
						72	1829	71-3/4	1822	70.444	1789

NOTE: For overall dimensions when using 3-1/2" dia. (89mm) donut bumpers: add 2-3/16" (56mm) to nominal depth, and 2" (51mm) to nominal length. When using 5-1/2" dia. (140mm) donut bumpers: add 4-3/16" (106mm) to nominal depth, and 4" (102mm) to nominal length.

Inside useable area of mat (between snake wires) for Super Erecta and Super Adjustable shelves: Length = nominal length - 3/4" (19mm). Depth = nominal depth - 1/2" (13mm).

Application Chart - SASE

Finish	Temp.	Abrasion	Chip Res.	Corrosion (Salt Spray)	Cut Through	Cart Wash	Finish Warranty	NSF Listed
Nickel Chrome	-20/120° F. -29/49° C.	Very Good	Excellent	Very Good	N/A	Not Recommended	1 Year	Yes
Brite	-20/120° F. -29/49° C.	Very Good	Very Good	Fair	N/A	Not Recommended	1 Year	Yes
Metroseal 3	-20/120° F. -29/49° C.	Excellent	Excellent	Excellent	Excellent	Not Recommended	12 Years	Yes
Stainless	-20/120° F. -29/49° C.	Excellent	Excellent	Excellent	N/A	Excellent	1 Year	Yes
Designer	-20/120° F. -29/49° C.	Good	Fair	Good	Fair	Not Recommended	1 year	No

TIM CAMPBELL 800-400-7500
SUPER ERECTA / SUPER ADJUSTABLE POST DETAIL

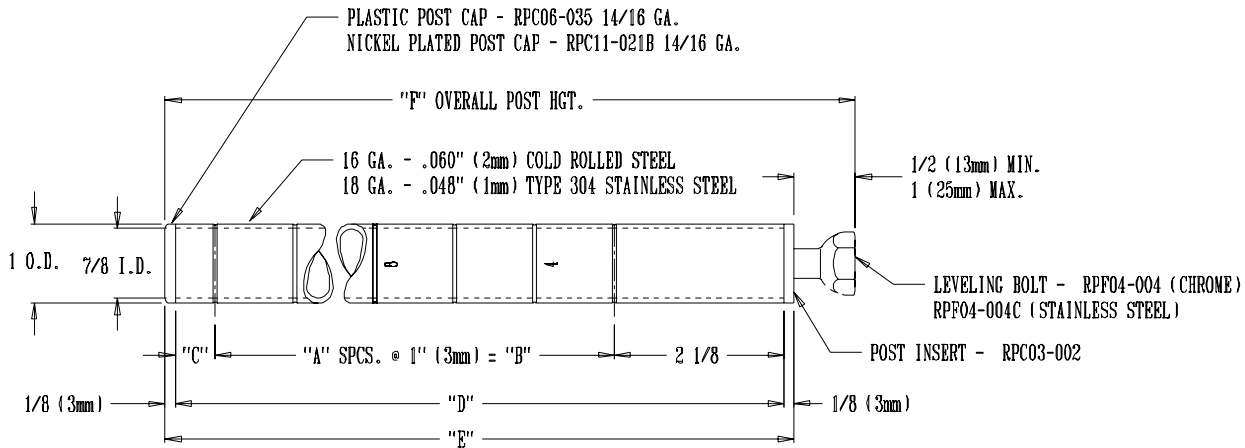

POST	"A" SPACES	DIM. "B"	DIM. "C"	DIM. "D"	DIM. "E"	*DIM. "F"
7P	4 (5 GROOVES)	4 (102mm)	1/2 (13mm)	6-5/8 (168mm)	6-7/8 (175mm)	7-5/8 (194mm)
13P	11 (12 GROOVES)	11 (279mm)	1/2 (13mm)	13-5/8 (346mm)	13-7/8 (352mm)	14-5/8 (371mm)
27P	25 (26 GROOVES)	25 (635mm)	1/2 (13mm)	27-5/8 (702mm)	27-7/8 (708mm)	28-5/8 (727mm)
33P	31 (32 GROOVES)	31 (787mm)	1/2 (13mm)	33-5/8 (854mm)	33-7/8 (860mm)	34-5/8 (879mm)
54P	51 (52 GROOVES)	51 (1295mm)	9/16 (14mm)	53-11/16 (1364mm)	53-15/16 (1370mm)	54-11/16 (1389mm)
63P	59 (60 GROOVES)	59 (1499mm)	9/16 (14mm)	61-11/16 (1567mm)	61-15/16 (1573mm)	62-11/16 (1592mm)
74P	71 (72 GROOVES)	71 (1803mm)	5/8 (16mm)	73-3/4 (1873mm)	74 (1880mm)	74-3/4 (1899mm)
86P	83 (84 GROOVES)	83 (2108mm)	5/8 (16mm)	85-3/4 (2178mm)	86 (2184mm)	86-3/4 (2203mm)
96P	93 (94 GROOVES)	93 (2362mm)	5/8 (16mm)	95-3/4 (2432mm)	96 (2438mm)	96-3/4 (2457mm)

*Dim. "F" is with leveling foot adjusted at midpoint - 3/4" (19mm).

Calculate Post Cut Length For Required Overall Height:

For Stem Casters = Required overall height - caster load height - 1/8 (3.2mm) = post cut length (round to next lowest 5/8"(16mm) if req'd. **Example No. 1** Required overall height of 38" (965mm) with HDC5BB caster = 38" (965mm) - 4-1/4" (108mm) - 1/8" (3.2mm) = 33 5/8" (854mm) post cut length.

Example No. 2 Required height of 37-1/2" (953mm) with 5MP caster = 37-1/2" (953mm) - 6-1/16" (154mm) - 1/8"(3.2mm) = 31-5/16"(795.4mm), rounded to next lowest 5/8" (16mm) = 30-5/8" (778mm).

Typ. Caster Load Hgts: HDC3B - 2-5/8" (67mm) 4LD - 4-5/8" (117mm)
 HDC3BB - 2-5/8" (67mm) All 5" Dia. Casters - 6-1/16" (154mm)
 HDC5B - 4-1/4" (108mm) 6MP - 7-1/16" (179mm)
 HDC5BB - 4-1/4" (108mm)

For Stationary Units (1" increments only) - Example: Overall Height requirement of 38" (965mm) = 38" (965mm) - 1-3/8"- (35mm) = 36-5/8" (930mm) post cut length. Yields 37-5/8"(956mm) overall height with leveler at midpoint - 37-3/8"(949mm) minimum/37-7/8"(962mm) maximum.

Super Erecta / Super Adjustable - Inside Clearance Between Posts

Depth	14	21	24	30	36
	11-5/8" (295mm)	18-5/8" (473mm)	21-5/8" (549mm)	27-5/8" (702mm)	33-5/8" (854mm)

Length	24	30	36	42	48	54	60	72
	21-3/8" (543mm)	27-3/8" (695mm)	33-3/8" (848mm)	39-3/8" (1000mm)	45-3/8" (1152mm)	51-3/8" (1305mm)	57-3/8" (1457mm)	69-3/8" (1762mm)

TIM CAMPBELL 800-400-7500

FINISH/PLATING:

Chrome - Nickel Chrome plating with a clear water based lacquer coating.

Super Brite - Zinc base chromate bath

Metroseal 3 – Proprietary cross linked epoxy coating applied by electrostatic process over a zinc plating substrate.

Stainless Steel – Electropolish finish on wire and small sheetmetal products. No. 3 finish (intermediate polish on both sides with uniform grain on one side) for stainless steel tables, cabinets, flat solid shelves, etc.

Designer Color: Epoxy powder coating.

SES/SASE WEIGHT CAPACITY

Shelf Length	Weight Capacity
24" thru 48" (610mm thru 1219mm)	800 lbs. (363 kg.)
54" thru 72" (1372mm thru 1829mm)	600 lbs. (272 kg.)

Note:

1. Load ratings are for evenly distributed static loads.
2. Maximum system load ratings for stationary units (4 shelf minimum) = 2000 lbs. (907 kg.)
3. Maximum load ratings for mobile units with stem casters = 1000 lbs. (454 kg.) or not to exceed three times the load rating for a single caster.
4. Maximum load ratings for mobile units with a dolly base = 1000 lbs. (454 kg.) or not to exceed three times the load rating for a single caster.

Super Erecta & Super Adjustable Super Erecta Stability Guidelines / Allowable Height	
Stationary Units (free standing without footplates or wall brackets)	
Shelf Depth	Maximum Allowable Post Height*
14" (356mm)	63" (1600mm)
18" (457mm)	86" (2184mm)
21" (533mm)	86" (2184mm)
24" (610 mm)	96" (2438mm)
30" (762mm)	96" (2438mm)
36" (914mm)	96" (2438mm)

*For all stationary units with footplates or wall brackets properly attached to the floor or wall, the maximum allowable post height is 96" (2438mm). Stationary units over 96" (2438mm) high are considered Hi-Rise applications and must be submitted to InterMetro engineering for review prior to approval. Consult your Metro representative for details.

Super Erecta & Super Adjustable Super Erecta Stability Guidelines / Allowable Height	
Mobile Units with stem casters	
Shelf Depth	Maximum Allowable Post Height
14" (356mm)	54" (1372mm)
18" (457mm)	74" (1880mm)
21" (533mm)	74" (1880mm)
24" (610 mm)	86" (2184mm)
30" (762mm)	86" (2184mm)
36" (914mm)	86" (2184mm)

