



TIM CAMPBELL 800-400-7500

Item # _____

Job _____



2-Shelf Cart



3-Shelf Cart

Deep Ledge Utility Carts

Metro's new Deep Ledge Utility Carts are designed for a wide variety of applications.

- 2³/₄" (70mm) deep ledge contains product and spills.
- Strong: each shelf can hold up to 150 lbs. (68kg); each unit can hold up to 400 lbs. (180kg).
- Cleanable, smooth surfaces are designed to resist staining and wipe clean easily.
- Easy to position center shelf option adjusts on 1" (25mm) increments.
- Ergonomic handle designed for easy use.
- Aesthetic design allows for use in a variety of applications.
- Available in four colors: stone, blue, berry, and black.
- Available in 20" x 30" (508 x 762mm) and 26" x 36" (660 x 914mm), 2- and 3-shelf models.
- Easy no-tool assembly. Shipped knocked down.
- NSF listed.



Stone



Blue



Berry



Black



Deep Ledge Utility Carts

Dimensions

Cat. No.*	Description	Width A		Length B		Height C		D		E		F		Approx. Pkd. Wt.	
		(in.)	(mm)	(in.)	(mm)	(in.)	(mm)	(in.)	(mm)	(in.)	(mm)	(in.)	(mm)	(lbs.)	(kg)
BC2030-2D	2-shelf unit	21 ¹ / ₂	546	32 ³ / ₄	832	41	1041	34 ¹ / ₂	876	21 ¹ / ₂	546	4 ¹ / ₂	114	29	21.1
BC2030-3D	3-shelf unit	21 ¹ / ₂	546	32 ³ / ₄	832	41	1041	34 ¹ / ₂	876	21 ¹ / ₂	546	4 ¹ / ₂	114	37 ¹ / ₂	17.0
BC2636-2D	2-shelf unit	27	686	38 ³ / ₄	984	41	1041	34 ¹ / ₂	876	21 ¹ / ₂	546	4 ¹ / ₂	114	35	15.9
BC2636-3D	3-shelf unit	27	686	38 ³ / ₄	984	41	1041	34 ¹ / ₂	876	21 ¹ / ₂	546	4 ¹ / ₂	114	46 ¹ / ₂	21.1

Carts available in 2-shelf and 3-shelf models.

*Colors available are: Stone (ST), Blue (BU), Berry (BY), and Black (BL).

*Add color designation to part number when specifying, i.e., BC2030-2DBL = 2-shelf Black unit.

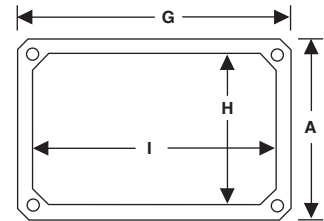
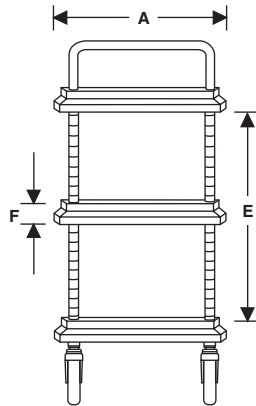
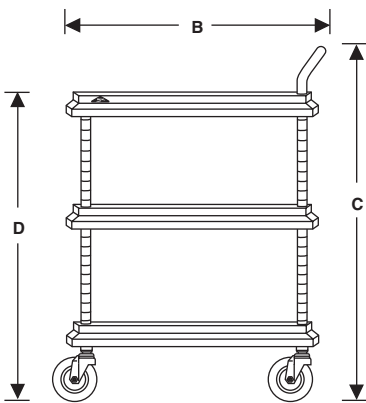

Additional Shelves†

Cat. No.*	Description	Width A		Length G		H		I		Approx. Pkd. Wt.	
		(in.)	(mm)	(in.)	(mm)	(in.)	(mm)	(in.)	(mm)	(lbs.)	(kg)
BC2030D-	Deep Ledge Shelf	21 ¹ / ₂	546	32	813	19	483	29	737	8.5	3.9
BC2636D-	Deep Ledge Shelf	27	686	38	965	24 ¹ / ₂	622	35	889	11.5	5.2

*Colors available are: Stone (ST), Blue (BU), Berry (BY), and Black (BL).

*Add color designation to part number when specifying, i.e., BC2030D-BL = 20" x 30" Black Deep Ledge Shelf.

†Not for shelving application.

Specifications

Cart, utility, consisting of at least 2 polyethylene, injection-molded shelves, chrome posts, and chrome-plated handle. 2-shelf cart design is such that user may add an intermediate shelf if deemed necessary. Cart will roll on four (4) 4" (102mm) diameter, resilient rubber casters. Cart rated at 150 lbs. (65kg) capacity per shelf, 400 lbs. (180kg) per unit.