



TIM CAMPBELL 800-400-7500

Item # \_\_\_\_\_

Job \_\_\_\_\_

## COMBINATION PROOFING/HOLDING CABINETS

### C175 FlavorView™ Series

- **Choose Proofing or Holding Mode:** CM2000 combination proofing/holding module changes from proofing to holding or vice versa at the flick of a switch. Adjust temperature and humidity individually. In proofing mode, one heating element below the water pan and one in the air stream are activated. In holding mode, one element in the air stream is activated. Blower-forced air circulation - at front, back and sides - assures uniform temperature throughout the cabinet. Wide, shallow chimney equalizes air circulation.
- **See Through Door:** The see-through door has dual magnetic latches which keep it closed securely. A full-length handle provides easy, one-handed opening by right- or left-handed operators. Door is field reversible. For transporting food in the holding mode, the cabinet is equipped with a transport latch.
- **Conserves Energy:** The door has a tough, clear window which permits viewing contents without opening the cabinet. Door is fully gasketed, preventing heat/humidity leakage.
- **Digital Thermometer:** Mounted in the unit with the sensing bulb stationary inside the cabinet for more consistent readings during frequent cabinet opening.
- **Easily Accessible Controls:** The control panel is recessed to protect controls and angled for easy viewing. All controls are on the outside, so they can be adjusted without opening the door and disturbing the atmosphere inside the cabinet.
- **Easy to Clean:** Slide racks, heat module, and chimney can be removed easily, without tools, for thorough cleaning. Model 4 racks come in two pairs to fit in pot sinks. Door can also be lifted off for easier access to interior.
- **Accommodates Various Tray Sizes:** Two slide options - 3" (76mm) spacing and 1½" (38mm) spacing - permit cabinets to accommodate various tray sizes. (See specifications on back.) Model 4 racks - with 3" (76mm) spacing - also adjust laterally to take both 18" (457mm) and 20" (508mm) width trays and pans.
- **Drip Trough:** Drip trough and removable pan contain condensation, preventing wet floor conditions.
- **Available In** Full and ¾ Height Models to accommodate a variety of applications.
- **2.6 Qt. Stainless Steel Water Pan.**



*C175 FlavorView™ Series*

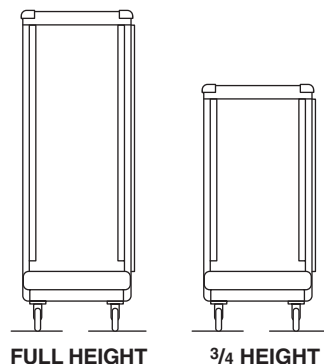

FULL HEIGHT

¾ HEIGHT



# COMBINATION PROOFING/HOLDING CABINETS

## C175 FlavorView™ Series

### Specifications

- Material:** .063" (1.8mm) high-strength, natural-finish aluminum, with brushed exterior surfaces. .125 chassis.
- Top & Bottom:** Brake-formed from flat sheet into box-shaped section.
- Sides & Back:** Brake-formed from flat sheet stock, with smooth, unobstructed interior walls for complete air circulation.
- Door:** Extruded aluminum frame with full-length clear window swings 270 degrees against side; double hinged; extruded aluminum full-length handle; continuous gasket; dual magnetic latches with transport latch. Door is field reversible.
- Tray Slide Racks:**
  - Model 4:** Nickel-chrome plated wire; 3" (76mm) slide spacing.
  - Model 8:** Custom-design aluminum extrusions with 1" x 1 1/2" x 1 1/8" (25 x 38 x 3mm) angle uprights and

1 1/2" x 1/2" x .063" (38 x 12 x 1.8mm) channel slides. All slide racks are removeable for thorough cleaning.

- Casters:** Two B5DN on back – 5" (127mm) double ball bearing swivel, ball bearing axle, nickel-plated, donut neoprene-tired, prelubricated, bolted through chassis. Two B5DNB on front – same as above, with wheel brake.
- Electrical:** CM2000 Combination Proofing/Holding Module – 1990 watt, 120 VAC, 16 amp, 60 cycle. Proof mode has separate adjustable temperature and humidity thermostats with separate indicator lights. Heat mode has adjustable temperature thermostat with indicator light. Cabinet operating range is 80°-120° Fahrenheit in proof mode and 80°-180° Fahrenheit in holding mode under normal room temperature conditions. Water pan,

continuous blower, perforated air duct at back, master switch and "Power On" light; 7 1/2-foot (2260mm), 3-wire lead cord with NEMA 5-20P straight male plug. Entire unit may be removed without tools. UL, CUL and NSF listed.

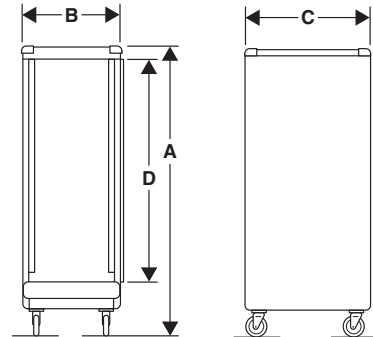

### Dimensions

#### Full Height

Cat. No.	(A) Height		(B) Width		(C) Depth		(D) Inside Height		Approx. Pkd. Wt.	
	(in.)	(mm)	(in.)	(mm)	(in.)	(mm)	(in.)	(mm)	(lbs.)	(kg)
C175-C8N	69 <sup>3</sup> / <sub>4</sub>	1772	25 <sup>3</sup> / <sub>16</sub>	640	32 <sup>1</sup> / <sub>16</sub>	814	53 <sup>3</sup> / <sub>4</sub>	1365	185	84
C175-C4N	69 <sup>3</sup> / <sub>4</sub>	1772	25 <sup>3</sup> / <sub>16</sub>	640	32 <sup>1</sup> / <sub>16</sub>	814	53 <sup>3</sup> / <sub>4</sub>	1365	197	90
C175-CVN*	69 <sup>3</sup> / <sub>4</sub>	1772	25 <sup>3</sup> / <sub>16</sub>	640	32 <sup>1</sup> / <sub>16</sub>	814	53 <sup>3</sup> / <sub>4</sub>	1365	213	97

#### 3/4 Height

Cat. No.	(A) Height		(B) Width		(C) Depth		(D) Inside Height		Approx. Pkd. Wt.	
	(in.)	(mm)	(in.)	(mm)	(in.)	(mm)	(in.)	(mm)	(lbs.)	(kg)
C175T-C8N	57 <sup>3</sup> / <sub>4</sub>	1467	25 <sup>3</sup> / <sub>16</sub>	640	32 <sup>1</sup> / <sub>16</sub>	814	41 <sup>3</sup> / <sub>4</sub>	1060	145	66
C175T-C4N	57 <sup>3</sup> / <sub>4</sub>	1467	25 <sup>3</sup> / <sub>16</sub>	640	32 <sup>1</sup> / <sub>16</sub>	814	41 <sup>3</sup> / <sub>4</sub>	1060	145	66
C175T-CVN*	57 <sup>3</sup> / <sub>4</sub>	1467	25 <sup>3</sup> / <sub>16</sub>	640	32 <sup>1</sup> / <sub>16</sub>	814	41 <sup>3</sup> / <sub>4</sub>	1060	145	66

\* Adjustable.

**NOTE:** Brakes are standard on two casters, for the units listed above.

### Accessories

Model	Description
PH175	Handle
B**	Corner Bumper
VS4N*	Extra Vari-slides (for C175-HVN only; will take 5 extra pair max.)

\* Standard on units listed above. May be added to previously purchased units.

\*\* Add bumper suffix to cabinet part number (i.e. C175-C8N-B).

#### Pan Capacity

Cat. No.	Slide Spacing		No. Full Ht.	No. 3/4 Ht.	Pan Size (in.)
	(in.)	(mm)			
"8N" Models	1 1/2	38	35	28	18 x 26
			17	13	20 x 24 x 2 1/4 (max.)
			14	13	20 x 24 x 2 5/8 (max.)
"4N" Models	3	76	28	26	12 x 20 x 2 1/4
			17	13	18 x 26
			17	13	14 x 18
			11*	9*	15 x 20 x 4 1/8
"VN" Models	Adjustable Min. 3	76	22*	18*	10 7/8 x 19 3/4 x 4 1/8 (max.)
			11*	9*	18 x 26 x 4 1/8 (max.)
			22*	18*	11 1/8 x 20 x 4 1/8 (max.)
			11*	9*	20 x 20 x 4 1/8 (max.)
			22*	18*	12 x 18 x 4 1/8 (max.)
			11*	9*	20 x 22 x 4 1/8 (max.)
			22*	18*	12 x 20 x 4 1/8 (max.)
			11*	9*	20 x 24 x 4 1/8 (max.)
			22*	18*	13 x 18 x 4 1/8 (max.)
			22*	18*	14 x 18 x 4 1/8 (max.)

\*Based on 4 1/2" spacing