



TIM CAMPBELL 800-400-7500

Item # _____

Job _____

METRO MOBILE PROOFING CABINETS C175 FlavorView™ Series

- **Ensures Uniform Proofing:** PM2X675 proofing module provides humidity and heat needed for yeast products (breads, rolls, donuts, etc.) to rise. Blower-forced air circulation, at front, back and sides, assures uniform temperature and humidity throughout the cabinet. Wide, shallow chimney equalizes air circulation and saves space.
- **See Through Door:** The see-through door has dual magnetic latches and a full-length handle which provides easy, one-handed openings by right- or left-handed operators, and is field reversible. A transport latch prevents the door from opening accidentally.
- **Maintains Controlled Environment:** The proofing module has separate controls for temperature and humidity, which provide flexibility in setting proofing conditions to suit the type of dough.
- **Easily Accessible Controls:** The control panel is recessed to protect controls and angled for easy viewing. All controls are on the outside, so they can be adjusted without opening the door and disturbing the atmosphere inside the cabinet.
- **Easy to Clean:** Slide racks, heat module, and chimney can be removed easily, without tools, for thorough cleaning. Model 4 racks come in two pairs to fit in pot sinks. The door can also be lifted off for easier access to interior.
- **Conserves Energy:** The door has a tough, clear polycarbonate window which permits viewing contents without opening the cabinet. Full gasket on door prevents heat and humidity loss through leakage.
- **Digital Thermometer:** Mounted in the unit with sensing bulb stationary inside the cabinet for more consistent readings during frequent cabinet opening.
- **Accommodates Various Tray Sizes:** Two slide options — 3" (76mm) spacing and 1½" (38mm) spacing — permit proofing cabinets to accommodate various tray sizes. (See specifications on back.) Model 4 and V racks, with 3" (76mm) spacing, also adjust laterally to take both 18" (457mm) and 20" (508mm) width trays and pans.
- **Drip Trough** and removable pan contain condensation, preventing wet floor conditions.
- **Available In** Full and ¾" height models to accommodate a variety of applications.
- **2.6 Qt. Stainless Steel Water Pan.**



C175-P8N

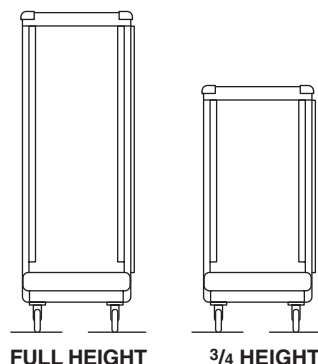

FULL HEIGHT

¾ HEIGHT

METRO MOBILE PROOFING CABINETS

C175 FlavorView™ Series



Specifications

- **Material:** .063" (1.8mm) high-strength, natural-finish aluminum, with brushed exterior surfaces. .188" (4.8mm) chassis.
- **Top & Bottom:** Brake-formed from flat sheet into box-shaped section.
- **Sides & Back:** Brake-formed from flat sheet stock, with smooth, unobstructed interior walls for complete air circulation.
- **Door:** Extruded aluminum frame with full-length clear window double hinged; extruded aluminum full-length handle; continuous gasket; dual magnetic latches with transport latch. Door is field reversible.
- **Tray Slide Racks:**
 - Model 4:** Nickel-chrome plated wire; 3" (76mm) slide spacing.
 - Model 8:** Custom-designed aluminum extrusions with 1" x 1½" x ⅛"
- (25 x 38 x 3mm) angle uprights and 1½" x ½" x .063" (38 x 12 x 1.8mm) channel slides. All slide racks remove for thorough cleaning.
- **Casters:** Two B5DN on back — 5" (127mm) double ball bearing swivel, ball bearing axle, nickel-plated, donut neoprene-tired, pre-lubricated, bolted through chassis. Two B5DNB on front — same as above, with wheel brake.
- **Electrical:** PM2X675 Proofing Module — 1350 watt, 120 VAC, 12 amp, 60 cycle, separate adjustable temperature and humidity thermostats with separate indicator lights. Cabinet operating range is 80° - 120° Fahrenheit under normal room temperature conditions. Water pan; continuous blower; perforated air duct at back; master switch and "Power On" light; 6-foot (1829mm), 3-wire lead cord with NEMA 5-15P straight male plug. Entire unit may be removed without tools, UL, CUL and NSF listed.

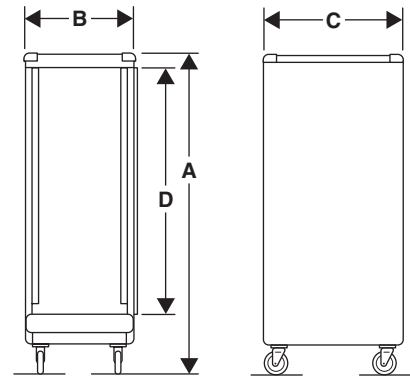

Dimensions

Full Height

Cat. No.	(A) Height		(B) Width		(C) Depth		(D) Inside Height		Approx. Pkd. Wt.	
	(in.)	(mm)	(in.)	(mm)	(in.)	(mm)	(in.)	(mm)	(lbs.)	(kg)
C175-P8N	69¾	1772	25⅜	640	32¼	815	53¾	1365	184	84
C175-P4N	69¾	1772	25⅜	640	32¼	815	53¾	1365	196	89
C175-PVN*	69¾	1772	25⅜	640	32¼	815	53¾	1365	212	96.2

*Adjustable

¾ Height

Cat. No.	(A) Height		(B) Width		(C) Depth		(D) Inside Height		Approx. Pkd. Wt.	
	(in.)	(mm)	(in.)	(mm)	(in.)	(mm)	(in.)	(mm)	(lbs.)	(kg)
C175T-P8N	57¾	1467	25⅜	640	32¼	815	41¾	1060	145	66
C175T-P4N	57¾	1467	25⅜	640	32¼	815	41¾	1060	145	66
C175T-PVN*	57¾	1467	25⅜	640	32¼	815	41¾	1060	145	66

*Adjustable

Accessories

Model	Description
PH175	Handle
B**	Corner Bumper
VS4N*	Extra Vari-slides (for C175-HVN only; will take 5 extra pr. max.)

*Standard on units listed above. May be added to previously purchased units.

**Add bumper suffix to cabinet part number (i.e. C175-P8N-B)

Pan Capacity

Cat. No.	Slide Spacing (in.) (mm)	No. Full Ht.	No. ¾ Ht.	Pan Size (in.)	
				3/4 Ht.	Pan Size (in.)
"8N" Models	1½ 38	35	28	18 x 26	
					17 13 20 x 24 x 2¼ (max.)
					14 13 20 x 24 x 2⅝ (max.)
					34 26 12 x 20 x 2¼
"4N" Models	3 76	28	26	12 x 20 x 2⅝	
					17 13 18 x 26
					17 13 14 x 18
					11* 9* 15 x 20 x 4⅛
"VN" Models	Adjustable Min. 3 76	11*	18*	10⅞ x 19¾ x 4⅛ (max.)	
					11* 9* 18 x 26 x 4⅛ (max.)
					22* 18* 11⅞ x 20 x 4⅛ (max.)
					11* 9* 20 x 20 x 4⅛ (max.)
					22* 18* 12 x 18 x 4⅛ (max.)
					11* 9* 20 x 22 x 4⅛ (max.)
					22* 18* 12 x 20 x 4⅛ (max.)
					11* 9* 20 x 24 x 4⅛ (max.)
					22* 18* 13 x 18 x 4⅛ (max.)
					22* 18* 14 x 18 x 4⅛ (max.)

*Based on 4½" spacing